

XY-WTH1 Temperature and Humidity Controller - MCLC.IR

Feature:

Model: XY-WTH1

Temperature range: -20 ° C ~ 60 ° C

Humidity range: 00%~100%RH

Control accuracy: 0.1 °C 0.1% RH

Detection probe: integrated sensor

Output type: relay output

Output capacity: up to 10A

Function:

Product features are two main types of classification: the functions of temperature and humidity.

The function of temperature are as follows:

1. The automatic identification of work mode:

The system automatically according to the start/stop temperature, identify work mode;

Start temperature > stop temperature, cooling mode 'C'.

Start temperature < stop temperature, heating mode 'H'.

2. Cooling mode:

When the temperature \geq Start temperature, relay conduction, red led on, refrigeration equipment begin to work;

When the temperature \leq Stop temperature, relay disconnect, red led off, refrigeration equipment stop to work;

3. Heating mode:

When the temperature \leq Start temperature, relay conduction, red led on, heating equipment begin to work;

When the temperature \geq Stop temperature, relay disconnect, red led off, heating equipment stop to work;

4. Temperature correction function OFE (-10.0 ~ 10 °C):

The system is working for a long time and may be biased, through this function correctly, the actual temperature = measuring temperature + calibration value;

How to set the start/stop temperature:

1. In the running interface, Long Press ' TM+ ' key more than 3 seconds, into the start temperature settings interface, can be modified by TM+ TM-key, to be modified, waiting for 6s automatic exit and save;
2. In the running interface, Long Press ' TM-' key more than 3 seconds, into the stop temperature settings interface, can be modified by TM+ TM-key, to be modified after the parameters, waiting for 6s automatic exit and save;

The humidity function is as follows:

1. The automatic identification of work mode:

The system automatically according to the start/stop humidity, identify work mode;

Start humidity > stop humidity, dehumidification mode 'D'.

Start humidity < stop humidity, humidification mode 'E'.

2. Dehumidification mode:

When the humidity \geq Start humidity, relay conduction, green led on, dehumidification equipment begin to work;

When the humidity \leq Stop humidity, relay disconnect, green led off, dehumidification equipment stops to work;

3. Humidification mode:

When the humidity \leq Start humidity, relay conduction, green led on, humidification equipment begin to work;

When the humidity \geq Stop humidity, relay disconnect, green led off, humidification equipment stops to work;

4. Humidification correction function RH (-10.0 ~ 10%):

The system is working for a long time and may be biased, through this function correctly, the actual humidity = measuring humidity + calibration value;

How to set the start/stop humidity:

1. In the running interface, Long Press ' RH+ ' key more than 3 seconds, into the start humidity settings interface, can be modified by RH+ RH- key, to be modified, waiting for 6s automatic exit and save;
2. In the running interface, Long Press ' RH-' key more than 3 seconds, into the stop humidity settings interface, can be modified by RH+ RH- key, to be modified after the parameters, waiting for 6s automatic exit and save;

Running Interface Description:

The working mode shows that the current mode ("H/C", "E/d") will be synchronized at the front of temperature/humidity, when the setting of temperature/humidity and stop temperature/humidity are completed.

Any relay conduction, the upper-left corner of the interface display "out", if the temperature relay conduction, the flashing display temperature working mode "H/C" to show reminders; if the humidity relay conduction, then flashing display humidity working mode "E/d", as a reminder;

Other features:

1. Parameter remote read/set:

Through the UART, set the starting temperature/humidity, stop temperature/humidity, temperature/humidity correction parameters;

2. Temperature/Humidity Real-time reporting:

If the temperature/humidity reporting function is turned on, the product will detect the temperature/humidity and relay status by the 1s interval, and pass the UART to the terminal to facilitate data collection;

3. Relay enabling (by default):

If the relay is disabled, the relay remains disconnected;

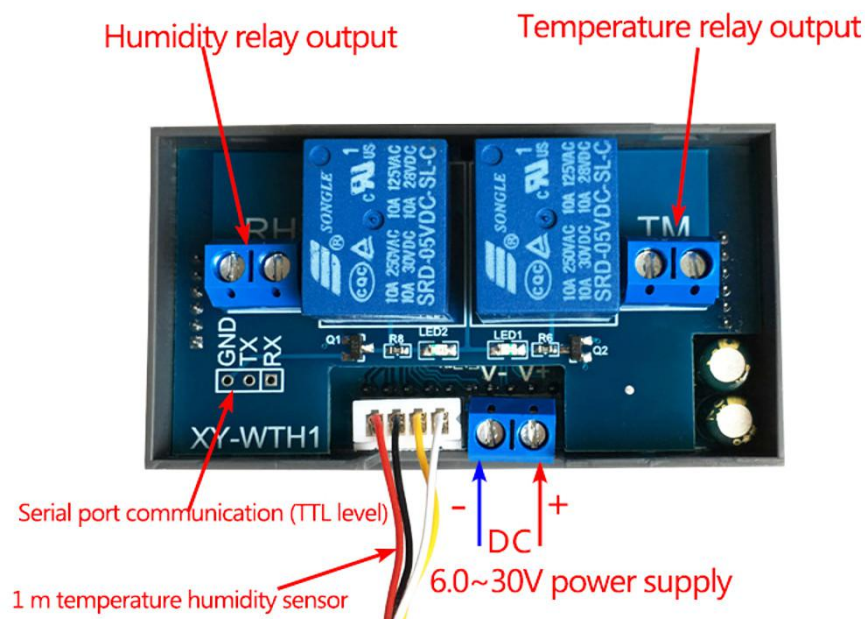

How to modify the temperature/humidity correction value:

1. In the operating interface, double-click the ' TM+ ' key to enter the correction of the set interface, the downward display correction of the type, the upward display of specific values; (OFE: Temperature correction value RH: Humidity correction value)
2. At this time by a short press ' TM-' key, switch to modify the parameters, through the RH+ RH-key, modify the specific value of the support long press short;
3. When the parameters have been modified, double-click the ' TM+ ' key, exit the correction positive setting interface, and save the data;

How to enable/disable relay:

In the running interface, Short press ' TM-' key, enable/disable the temperature relay(ON: enable OFF: disable), back to the running interface, if the temperature relay is disabled, the temperature symbol ' °C ' flashes to remind.

In the running interface, Short press ' RH-' key, enable/disable the humidity relay (ON: enable OFF: disable), back to the running interface, if the humidity relay is disabled, the humidity symbol '% ' flashes, as a reminder.

Serial control(TTL level)

BaudRate:9600bps Data bits :8

stop bits :1

crc :none

Flow control :none

CMD	Description
Start	start data upload
Stop	stop data upload
Read	Read the param setting
T: ON	Temperature relay enable
T: OFF	Temperature relay disable
H: ON	Humidity relay enable
H: OFF	Humidity relay disable
TS: XX.X	Set start Temperature (-20.0~60.0)
TP: XX.X	Set stop Temperature (-20.0~60.0)
HS: XX.X	Set start Humidity (00.0~100.0)
HP: XX.X	Set stop Humidity (00.0~100.0)
TC: XX.X	Set Temperature Calibration (-10.0~10.0)
HC: XX.X	Set Humidity Calibration (-10.0~10.0)

Temperature and humidity Data upload format Description:

Temperature format: Operating mode (H/C), temperature value, temperature relay status;

Humidity Format: Operating mode (E/D), humidity value, humidity relay status;

H, 20.5 °C , CL: Heating operating mode, the current temperature of 20.5 degrees, temperature relay disconnection state;

D, 50.4%,OP:Dehumidification working mode, current humidity 50.4%, humidity relay connection;



Any relay relay indicates OUT.



